

CZIP[®]-CR2

MV BAY CONTROLLER

DIGITAL PROTECTION, AUTOMATION, MEASUREMENT,
CONTROL, RECORDING, AND COMMUNICATION SYSTEM
FOR FEEDER AND OUTGOING BAYS

CZIP®-CR2

MV BAY CONTROLLER

The **CZIP®-CR2** MV Bay Controller is an integrated system for protection, measurement, control, communication, recording and interaction with substation automation systems. It is designed for feeder and outgoing bays in medium-voltage power networks.

Developed and continuously enhanced in close collaboration with end users, the **CZIP®-CR2** combines Lumel's extensive experience in protection relay design with the latest advancements in electronic component technology. As a result, it represents one of the most advanced and versatile protection and control systems in its class.



- **CZIP®-CR2** – for medium-voltage switchgear in industrial and utility power distribution systems
- **CZIP®-Set** – For configuration, parameterization, and management of all **CZIP®** system devices, including **CZIP®-CR** MV Bay series controllers.

CHARACTERISTIC

CZIP®-CR2 – DIGITAL MV BAY CONTROLLER

- **Support for programmable logic (up to 50 logic functions)**
- 7" color TFT LCD touchscreen, 800×480 resolution
- Graphical single-line diagram of the bay with real-time indication of switchgear status
- Control of up to 11 switching devices directly from the synoptic screen or via SCADA/telecontrol
- Display of recorded events, measurement values, and I/O states
- **28 opto-isolated binary inputs**
- **20 relay outputs**
- 14 dual-color programmable LEDs with customizable on-screen labels
- ON and OFF push-buttons for local circuit breaker control from the front panel
- 512 MB internal memory for disturbance recorder files, event logs, and energy measurement data
- Time synchronization via Ethernet using the SNTP protocol
- Independent communication interfaces: USB, 2×RS-485, Ethernet 10/100BASE-TX
- Supported communication protocols: DNP3.0, IEC 60870-5-103/104, IEC 61850, Modbus® ASCII/RTU
- Selectable application modes available from the device menu

FUNCTIONS

Protections	Automation
Three-stage overcurrent protection against interphase short-circuits	SPZ
Directional blocking for each stage of overcurrent protection	SCO – 3 stages
Instantaneous protection against making on to a fault	SPZ/SCO
Second harmonic restraint for phase overcurrent protections	LRW
Zero-sequence current (earth fault) protection	
Zero-sequence voltage as a starting element for other protections	
Zero-sequence voltage used as an independent protection criterion	
Admittance-type earth fault protection	
Overfrequency protection	
Underfrequency protection	
Frequency df/dt	
Overcurrent element of busbar protection blocking scheme	
Directional restraint for busbar overcurrent blocking element	
Decision-making unit of busbar protection	
Overcurrent-logical busbar protection	
Overvoltage protection	
Undervoltage protection	
Directional active reverse power protection P3>	
Directional reactive reverse power protection Q3>	

TECHNICAL DATA

Phase current input circuits		Relay output circuits	
CURRENT TRANSFORMERS		Rated contact voltage	
Rated current I_n	5 A or 1 A	250 V a.c.	
Measuring range	0...200 A	Continuous current load capacity	
Measurement error	0.05 A > 0.35...50 A < 200 A < 10% < 1.5% < 10%	5 A	
Rated frequency f_n	50 Hz	Opening of inductive circuit	
Power consumption $I=I_n$	< 0.5 VA	• 250 V d.c., L/R = 40 ms 0.1 A	
Phase voltage input circuits		• 240 V a.c., $\cos \varphi = 0.4$ 2 A	
Rated voltage U_n	100 V	Breaker cooperation circuits	
Measuring range	0...130 V	Rated contact voltage	
Measurement error	< 1.5%	250 V a.c.	
Rated frequency f_n	50 Hz	Continuous current load capacity	
Power consumption at $U=U_n$	< 0.4 VA	8 A	
Zero-sequence current input circuits		Opening of inductive circuit	
Rated current I_{0n}	0.5 A	• 220 V d.c., L/R = 40 ms 1.2 A / 300 cycles	
Measuring range	0...5 A	Duration of trip pulse	
Measurement error	0.003 A > 0.02...3,5 A < 5 A < 10% < 1.5% < 10%	min. 0.1 s	
Rated frequency f_n	50 Hz	Duration of closing pulse	
Power consumption at $I=I_{0n}$	< 0.1 VA	0.2 ÷ 1 s	
Zero-sequence voltage input circuits		Other Data	
Rated voltage U_{0n}	100 V	Power Supply	
Measuring range	0...130 V	• Rated supply voltage	
Measurement error	< 1.5%	220 V d.c. 230 V a.c. 24 V d.c.	
Rated frequency f_n	50 Hz	110...220...265 V 85...230...265 V 19...24...60 V	
Power consumption at $U=U_{0n}$	< 0.4 VA	• Power consumption < 20 W	
Binary input circuits		Environmental conditions	
Rated input voltage	230 V a.c. 24 V d.c. 220 V d.c. 110 V d.c.	• ambient temperature -10...+55°C	
Current consumption	< 3 mA	• storage temperature -20...+70°C	
		• altitude above sea level ≤ 2000 m	
		• relative humidity 5...95%	
		Weight 6 kg	
		Dimensions 300 x 180 x 150 mm	
		Enclosure protection degree IP50 on the front side IP20 on the terminal side	

CZIP[®]-CR2

MV BAY CONTROLLER

DIMENSIONS

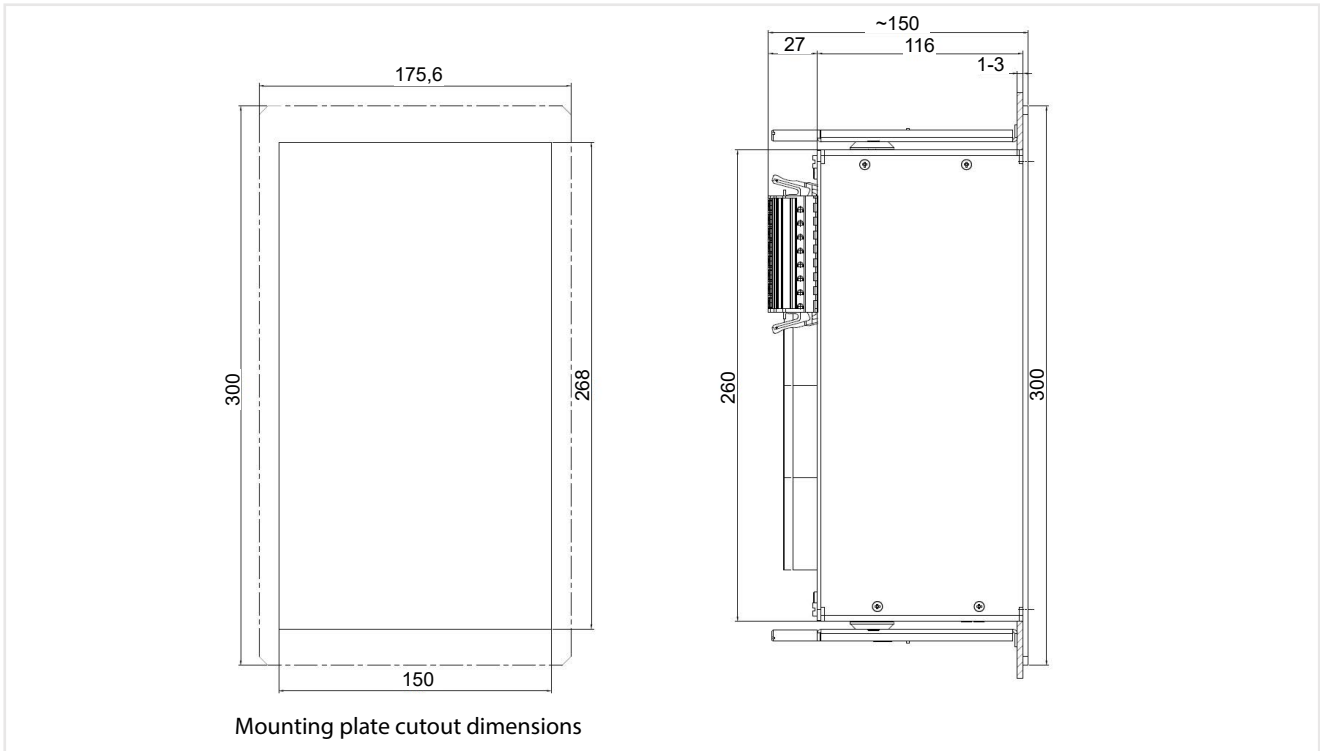

CZIP[®]-SET SOFTWARE

- software supplied with extCZIP[®]-PRO devices,
- excellent engineering tool supporting the user in specifying settings, configuring all available parameters, checking current configuration, measurement data and event recorder,
- a module enabling reading of samples saved in the disturbance recorder and their comprehensive analysis is also included in the software package,
- the tool includes a programmable logic editor, which enables adaptation of the extCZIP[®]-PRO device to individual needs and solutions,
- software enables communication with extCZIP[®]-PRO devices via RS-485 serial ports, optical fiber, USB, Ethernet,
- comparator of configuration files,
- synoptic editor - standard connectors + 11 configurable ones,
- remote control of MV and LV switches via Ethernet (VPN).

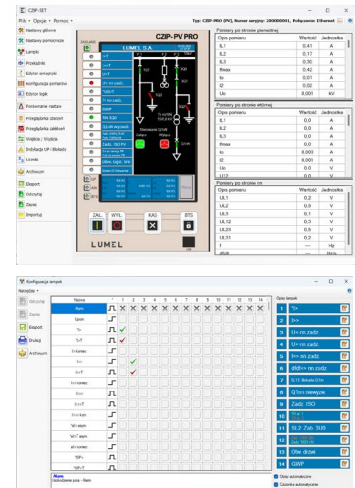

ORDERING CODE

	CZIP CR2	X	X	X	X	X	X	X	X	X	X	XXX	X
Type	Industrial (4I4U)	1											
	Industrial + sensors (4U 3I+I0)*	2											
Rodzaj styku wyjścia sygn. ALARM	Parallel	1											
	Series	2											
Wersja	Screw terminals			2									
	spring-clamp terminals			4									
Power supply voltage	85...230...265 V a.c. ; 50 Hz/ 110...220...265 V d.c.				1								
	19...24...60 V d.c.				2								
Binary input voltage	230 V a.c. (for a supply voltage of 85...265 V a.c.;110...265 V d.c.)					1							
	24 V d.c. (for a supply voltage of 19...60 V d.c.)					2							
	220 V d.c. (for a supply voltage of 85...265 V a.c.;110...265 V d.c.)					3							
	110 V d.c. (for a supply voltage of 85...265 V a.c.;110...265 V d.c.)					4							
Number of binary inputs	28							0					
Number of relay outputs	20								1				
Special functions	None									0			
	PT 100*									1			
Language version	Polish										0		
	English										E		
	Other										X		
Variant	Standard											000	
	Special											XXX	
Acceptance tests	Without additional requirements												0
	With calibration certificate												2
	As agreed with customer												X

* applies to motor protection version.

LUMEL

LUMEL S.A.

ul. Słubicka 4,
65-127 Zielona Góra, Poland
tel.: +48 68 45 75 100

Technical support:

tel.: (+48 68) 45 75 143,
45 75 141, 45 75 144, 45 75 140
e-mail: export@lumel.com.pl

Export department:

tel.: (+48 68) 45 75 130,
45 75 131, 45 75 132
e-mail: export@lumel.com.pl

Calibration & Attestation:

e-mail: laboratorium@lumel.com.pl

www.lumel.com.pl/en/

Follow us  