

LUMEL

TRANSDUCER
OF RMS CURRENT OR AC VOLTAGE

P20Z



USER'S MANUAL

CE

CONTENTS

1. APPLICATION	5
2. TRANSDUCER SET	5
3. BASIC REQUIREMENTS and OPERATIONAL SAFETY	5
4. INSTALLATION	7
5. TECHNICAL DATA.....	9
6. EXECUTION CODES.....	12
7. MAINTENANCE and GUARANTEE.....	13

1. APPLICATION

The P20Z transducer is destined for a continuous conversion of the RMS current or ac voltage without a constant component into a constant-current or constant-voltage standard signal.

The transducer output signal is galvanically isolated from the input signal and supply. The transducer housing is made of a plastic. On the transducer outside, there are inseparable screw or socket-plug terminal strips.

2. TRANSDUCER SET

The set of the P20 transducer is composed of:

1. P20Z transducer 1 pc.

When unpacking the transducer, please check whether the type and execution code on the data plate correspond to the order.

3. BASIC REQUIREMENTS and OPERATIONAL SAFETY

In the safety service scope, the transducer meets the requirements of the EN 61010-1 standard.



Observations concerning the operational safety

- All operations concerning transport, installation, and commissioning as well as maintenance, must be carried out by qualified, skilled personnel, and national regulations for the prevention of accidents must be observed.

- Before switching the transducer on, one must check the correctness of connection to the network.
- Do not connect the transducer to the network through an autotransformer.
- Before removing the transducer housing, one must switch the supply off and disconnect measuring circuits.
- The removal of the meter housing during the guarantee contract period may cause its cancellation.
- The P20Z transducer is destined to be installed and used in industrial electromagnetic environment conditions.
- One must remember that in the building installation a switch or a circuit-breaker should be installed. This switch should be located near the device, easy accessible by the operator, and suitably marked.

4. INSTALLATION

4.1 Fitting.

The P20Z transducer is adapted to be mounted on a 35 mm rail acc. to EN 60715.

The overall drawing and the fitting way are presented on the fig. 1.

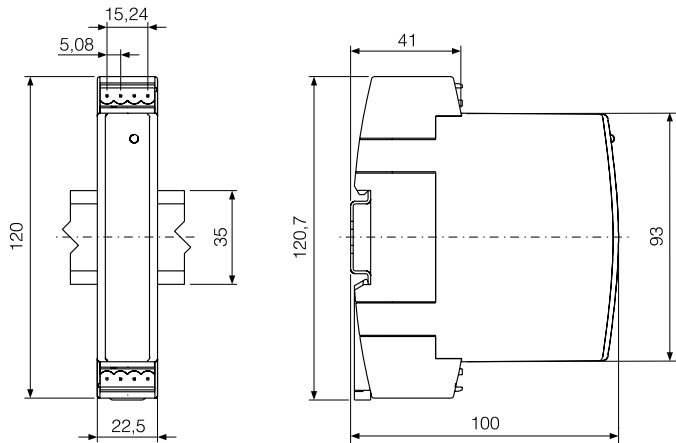
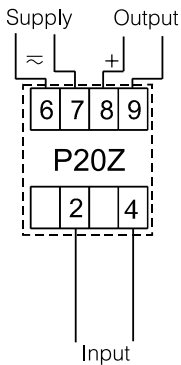

Fig.1 Overall drawing and transducer fitting way.

4.2. External connection diagrams

One must carry out external connections with wires of maximal diameters:

- 2,5 mm² for socket-plug executions,
- 1,5 mm² for screw executions.



Direct measurement of voltage

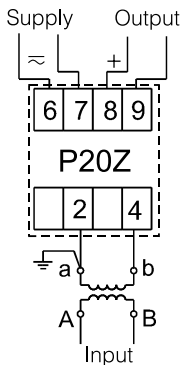

Indirect measurement of voltage by means of a voltage transformer

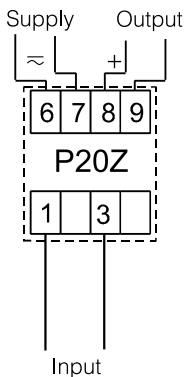

Direct measurement of current

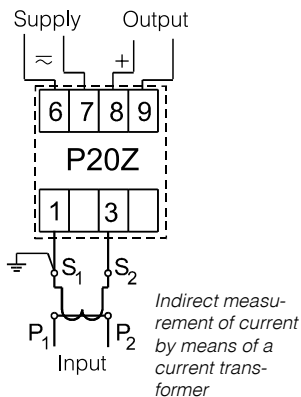

Indirect measurement of current by means of a current transformer

Fig. 2. External connection diagrams of the P20Z transducer

5. TECHNICAL DATA

Basic parameters:

- input voltage	60, 100, 150, 250, 400, 500, 600 V~
- input current	1 A (X/1 A~), 5 A (X/5 A~)
- output signal	0... 5 mA $R_{load.} \leq 2000 \Omega$ 0... 20 mA $R_{load.} \leq 500 \Omega$ 4... 20 mA $R_{load.} \leq 500 \Omega$ 0... 10 V $R_{load.} \geq 500 \Omega$
- response time	0.3 sec
- accuracy class	0.2
- transducer preheating time	15 min.

Consumption:

- in supply circuit	≤ 4 VA
- in voltage circuit	≤ 0.6 VA
- in current circuit	≤ 0.2 VA

Supply voltage 85...253 V or 20...40 V d.c. or a.c.

Protection level ensured by the housing IP 50

Protection level ensured from the terminal side IP 20

Weight 0.125 kg

Overall dimensions 22.5 × 120 × 100 mm

Fitting on a 35 mm rail

Maximal wire section 2.5 mm²
for executions with screw terminals
1.5 mm²
for executions with self-locking terminals

Reference and rated operating conditions:

- input signal	0... <u>0.01</u> ... <u>1.2</u> I _n ; 0... <u>0.01</u> ... <u>1.2</u> U _n
- frequency of the input signal	<u>45</u> ... <u>65</u> ...500 Hz
- supply	85...253 V a.c.,90...300 V d.c. 20...40 V a.c.,20...60V V d.c.
- admissible peak factor:	
- current	2
- voltage	2
- ambient temperature	- 20... <u>23</u> ...55°C
- storage temperature	- 25... +85°C
- relative humidity	95% (inadmissible condensation)
- external magnetic field	<u>0</u> ... <u>40</u> ...400 A/m
- short duration overload (5 s):	
- voltage input	2 U _n (max.1000 V)
- current input	10 I _n
- working position	any

Additional errors:

In multiplicity of the class index:

- from ambient temperature changes	< 0.5 k/10 K
- external magnetic field	< 1 k
- frequency of the input signal	< 1 k/100 Hz

Standards fulfilled by the transducer

Electromagnetic compatibility:

- immunity acc. to EN 61000-6-2
- emission acc. to EN 61000-6-4

Safety requirements:

Acc.to the EN 61010-1 standard

- Isolation ensured by the housing: double,
- Isolation between circuit: basic,
- Pollution degree 2,

For voltages in relation to earth, up to 300 V

- installation category III,

For voltages in relation to earth, up to 600 V

- installation category II,

Altitude above sea level < 2000 m

6. EXECUTION CODES

Execution codes of the P20Z transducer

Table 1

Transducer	P20Z -	XX	X	X	X	XX	X
Input range:							
0... 60 V.....		01					
0... 100 V.....		02					
0... 150 V.....		03					
0... 250 V.....		04					
0... 400 V.....		05					
0... 500 V.....		06					
0... 600 V.....		07					
0... 1 A		08					
0... 5 A		09					
Output range:							
0... 5 mA.....		1					
0... 20 mA.....		2					
4... 20 mA.....		3					
0... 10 V.....		4					
Supply voltage:							
85...253 V a.c.,90...300 V d.c.....		1					
20...40 V a.c.,20...60V V d.c.		2					
Kind of terminals:							
inseparable screws		1					
Socket-plug screws.....		2					
Kind of execution:							
standard		00					
Custom-made		XX					
Próby odbiorcze							
Without extra quality requirements		8					
With an extra quality inspection certificate.....		7					
Acc. to customer's requirements*.....		X					

* after agreeing with the manufacturer.

Example of order:

When ordering, please respect successive code numbers.

The code: **P20Z-09 3 1 1 00 8** means:

- P20Z** – transducer of RMS current and a.c. voltage
- 09** – with current input: 0... 5 A,
- 3** – output range: 4... 20 mA,
- 1** – supply voltage: 85...253 V a.c., 90...300 V d.c
- 1** – kind of terminals: inseparable screws,
- 00** – standard execution
- 8** – without extra quality requirements

7. MAINTENANCE and GUARANTEE

The P20Z transducer does not require any periodical maintenance.

In case of some incorrect operations:

After the dispatch date and in the period stated in the guarantee card:

One should return the instrument to the Manufacturer's Quality Inspection Dept. If the instrument has been used in compliance with the instructions, we warrant to repair it free of charge. The disassembling of the housing causes the cancellation of the granted guarantee.

After the guarantee period:

One should turn over the instrument to repair it in a certified service workshop.

Spare parts are available for the period of five years from the date of purchase.

Our policy is one of continuous improvement and we reserve the right to make changes in design and specifications of any products as engineering advances or necessity requires and revise the above specifications without notice.



LUMEL

LUMEL S.A.

ul. Słubicka 4, 65-127 Zielona Góra, Poland
tel.: +48 68 45 75 100, fax +48 68 45 75 508
www.lumel.com.pl

Informacja techniczna:

tel.: (68) 45 75 140, 45 75 141, 45 75 142, 45 75 145, 45 75 146
e-mail: sprzedaz@lumel.com.pl

Realizacja zamówień:

tel.: (68) 45 75 150, 45 75 151, 45 75 152, 45 75 153, 45 75 154,
45 75 155

Wzorcowanie:

tel.: (68) 45 75 163
e-mail: laboratorium@lumel.com.pl

Technical support:

tel.: (+48 68) 45 75 143, 45 75 141, 45 75 144, 45 75 140
e-mail: export@lumel.com.pl

Export department:

tel.: (+48 68) 45 75 130, 45 75 132
e-mail: export@lumel.com.pl

Calibration & Attestation:

e-mail: laboratorium@lumel.com.pl